

Design and Analysis of a Switched Reluctance Motor Using EMS

Robert Lupoiu, Abdullah Mubushar, Kevin Ivo, and Daniel Li
Department of Electrical Engineering, University of British Columbia

Abstract—This whitepaper summarizes the use of the EM-Works Electromagnetic Simulation (EMS) software in designing a fully custom switched reluctance motor, for partially fulfilling the requirements of the third year project course Electrical Engineering Design Studio II, part of the Undergraduate Electrical Engineering degree at the University of British Columbia, Vancouver. To build a motor that meets all project design criteria under the course’s design constraints, accurate simulation modeling is a crucial part of the design process. This paper highlights how EMS was integrated into the motor’s iterative design process, how it was used to estimate the final design’s characteristics, and it compares a prototype with the simulation results. The authors highly recommend EMS for the design of any electromagnetic product or system.

I. INTRODUCTION

THE switched reluctance motor is one of the most versatile, efficient, and popular electrical motor types. [1] The third year design course project for which this motor was made required two such reluctance motors to control a four-bar linkage that handles a mallet used to play music on a glockenspiel (a percussion musical instrument). The motor thus required very specific performance characteristics to satisfy the needs of the control system’s hardware and software. It was determined that the motors would require final characteristics as summarized in Table 1 to achieve adequate controls performance.

TABLE I: Motor nominal characteristic requirements.

Torque ($N \cdot m$)	Speed (rpm)
0.02	1000

The team was constrained by the course to using a maximum of ten waterjet-cut laminations for the rotor and stator, with a maximum thickness of 11 gauge low-carbon, hot rolled steel, with 0.15mm powder coating for electrical insulation. Furthermore, given the financial constraints of the project, it was not possible to finalize the design by iterating physical prototypes. Integrating accurate design software into the design process was imperative. The magnetostatic study, transient magnetic analysis, and seamless SolidWorks motion study integration features make EMS [2] the perfect tool for any such electromagnetic machine design process.

R. Lupoiu, A. Mubushar, K. Ivo, and D. Li are with the Department of Electrical Engineering, University of British Columbia, Vancouver, BC, V6T 1Z4 Canada (e-mails: rclupoiu@ece.ubc.ca, Amubushar@alumni.ubc.ca, zhl.kvz@gmail.com, danielyzli222@alumni.ubc.ca)

This whitepaper highlights the integration of EMS within the design process. The final motor design is depicted in Fig. 1. EMS was used to both justify fundamental design decisions and optimize the outer stator and inner rotor of the motor, as shown (along with a prototype encasing, shaft, and coils) in Fig. 1. In this paper, some of the most important features of EMS are highlighted through a summary of the simulation-driven design process, a presentation of the simulated performance results of the final product, and through validation of the baseline simulation performance results by measuring the characteristics of a physical prototype.

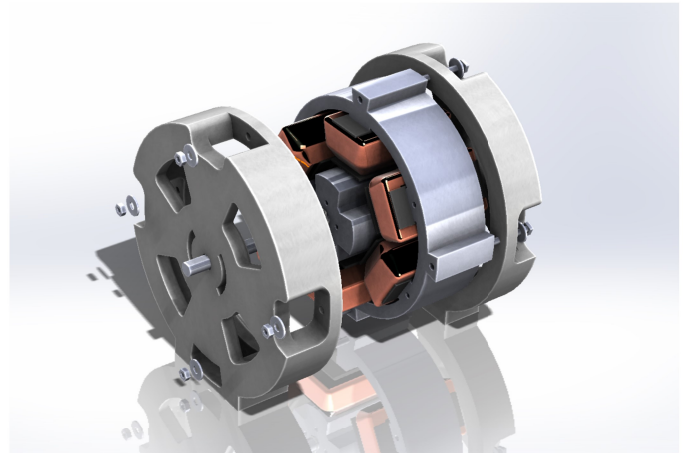

Fig. 1: 3D rendering of the finalized switched reluctance motor, complete with the EMS-designed stator and rotor, coils, and prototype enclosure.

II. SIMULATION-DRIVEN DESIGN

To localize onto a design that efficiently meets the characteristic requirements of the motor, an iterative, simulation-driven design process was utilized. As illustrated in Fig. 2, several holes are necessary in both the rotor and the stator for assembling the final motor. To maximize the efficiency of the motor, all holes must be placed such that they impede the path of the magnetic flux through the steel as little as possible. As Fig. 2 illustrates for the rotor, several designs were considered, with differing hole placements, before choosing a final design. Below, the hole placements are carefully justified using EMS simulations.

An important feature of EMS is the ability to fine-tune the mesh size around features of parts within the SolidWorks assembly. The software has the ability to use more coarse

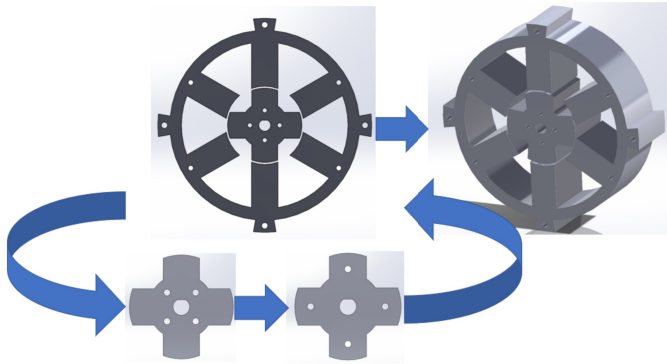

Fig. 2: The iterative design process was used to justify critical design decisions. Above, it is illustrated how different rotor designs were tried before settling on the one that least impeded the path of magnetic flux within the magnetic circuit, formed by energizing a coil wound in series over diametrically opposing stator poles. The final design is the one illustrated in the top-right of the figure.

meshing in regions of the assembly where there are less detailed features, increasing simulation speed, while giving the user the ability to use fine meshing in regions where capturing finer details is paramount, such as the screw holes of the rotor, as illustrated in Fig. 3.

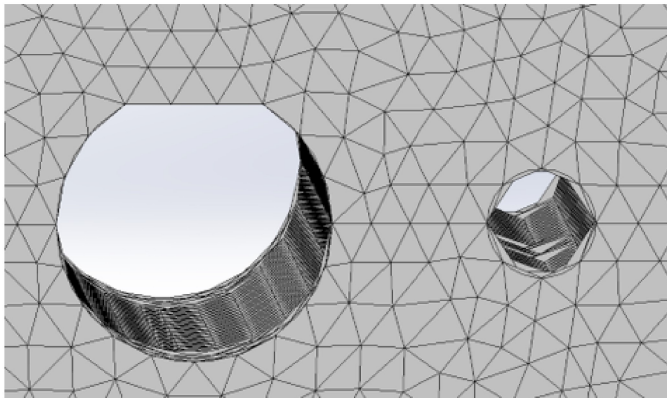

Fig. 3: EMS gives the user fine control over the meshing of different parts within a SolidWorks assembly. It is illustrated how the meshing in the rotor was chosen to be fine enough to capture all critical features, yet not so fine as to unnecessarily increase simulation time.

EMS supports the study of magnetic flux paths through both heat maps, as in Fig. 4, and through vectors that help visualize magnitude through color-coding and varying size, as in Fig. 5. In Fig. 4, the heatmap is used to determine the optimal placement of the watercooling tube channels in the stator. When maximum flux is flowing through the stator, when adjacent coils are energized, it is evident that the least flux flows behind the poles (the protrusions that extend towards the rotor, around which the coils are wound). The farthest-spaced, diametrically-opposing holes are for enclosure mounting screws. Fig. 5(a) illustrates the flux paths within the rotor. The screw holes are placed as close to the shaft as

possible, to be well out of the way of the flux path when at its maximum, as depicted by the red and orange vectors in the figure. Fig. 5(b) justifies the use of a slightly wider rotor pole than stator pole: a slight overhang allows the flux to "bite" into the rotor, resulting in smoother torque and speed profiles. The width was incrementally changed and the motor's motion was simulated to determine the optimal width, essentially trading off smoothness of profile with maximum magnitude of speed and torque.

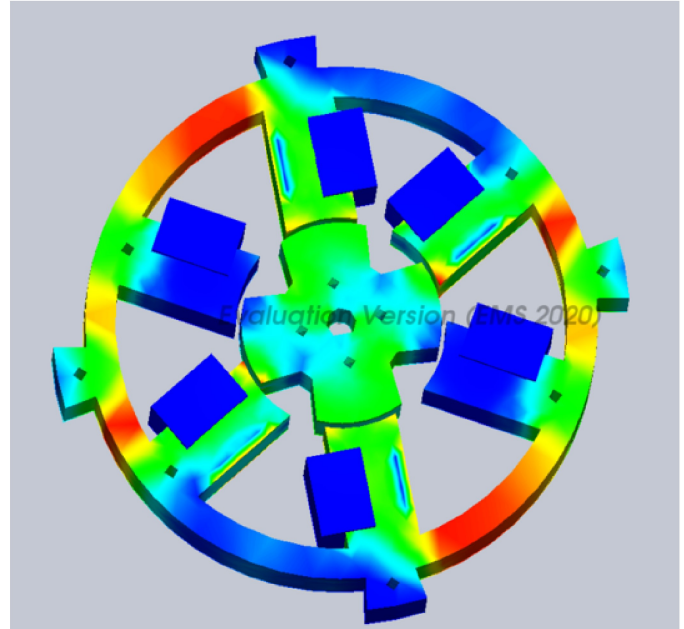
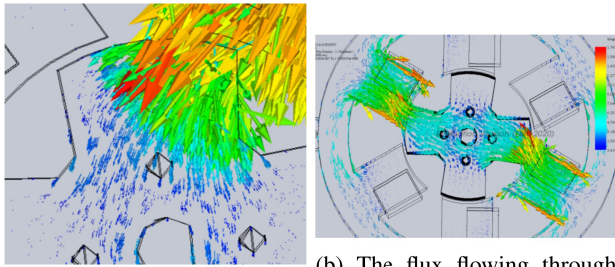

Fig. 4: A heat map can be used to study the magnetic flux density within the assembly. In this case, the simulation is used to place watercooling tube channels by determining that the least flux within the outer stator ring flows at the ends of the stator poles when the maximum amount of flux flows through the assembly.

Similar iterative processes were used to determine the design features of the motor, from the self-starting 6/8 rotor-stator pole count configuration to the thickness of the outer stator ring. The final design is fully simulated, and the relevant values are collected and presented in the following section.

III. PERFORMANCE SIMULATIONS

EMS makes preparing the SolidWorks assembly for simulation straightforward and time-efficient. As described in section II, the user is given fine control over the meshing size over the assembly, allowing optimization of simulation speed vs. precision of results. The meshing of the SolidWorks motor assembly is illustrated in Fig. 6. EMS uses purple vectors to help visualize the parts of the assembly that are prepared for simulated torque studies. In this case, as shown in Fig. 6, the rotor part of the motor assembly is prepared for torque simulation. For EMS Transient Magnetic Analysis, the user has complete control over the current definitions. As visualized by EMS with green vectors in Fig. 7, the current directions into and out of the coils, which are diametrically wired in series



(a) Close-up of the magnetic flux flowing through the rotor, the slightly wider rotor poles justifying the placement of the screw holes. They are placed level out the speed and torque well out of the way of the profiles of the motor, by allowing maximum flux density, which into the magnetic flux to "bite" is illustrated by the larger red and orange vectors.

(b) The flux flowing through the entire assembly, justifying the placement of the rotor and stator poles.

Fig. 5: The use of the magnetic flux vector visualization of EMS is illustrated. (a) justifies the placement of the screw holes within the rotor, and (b) justifies the relative width of the rotor and stator poles.

for this motor, are specified. The number of turns and wire gauge for each, individual, coil are also specified as 300 turns and 25 AWG, respectively. Finally, the precise materials, with their magnetic properties pre-set within EMS, such as copper wires and low-carbon steel for the laminations, are defined in the assembly, as illustrated in Fig. 7.

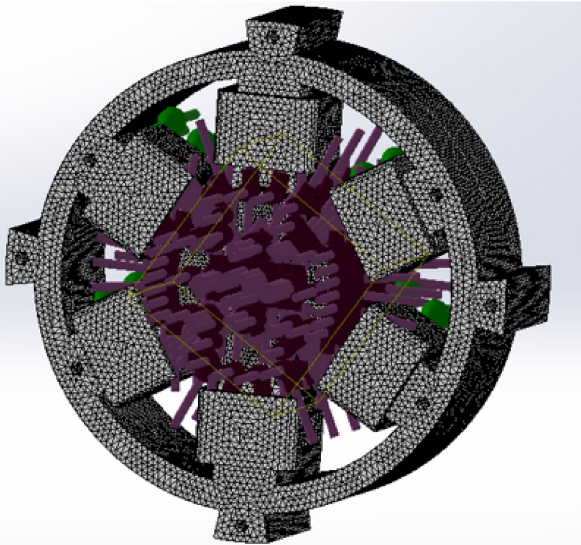

Fig. 6: The parts onto which torque simulation studies are performed by EMS are specified in the SolidWorks assembly, and visualized using purple vectors in the figure. The meshing of the assembly is also illustrated.

As shown in Fig. 8, the 2A-amplitude currents through the coils are defined to turn the rotor at 1,000 RPM. As shown by the torque output of the simulation in Fig. 9, the motor is capable of a maximum of $0.028 N \cdot m$ of torque, with a ripple of about 0.2%. The periodic pattern indicates that the motor is comfortable running at the target 1,000 RPM. The flux linkage data between coils over time is also collected and presented

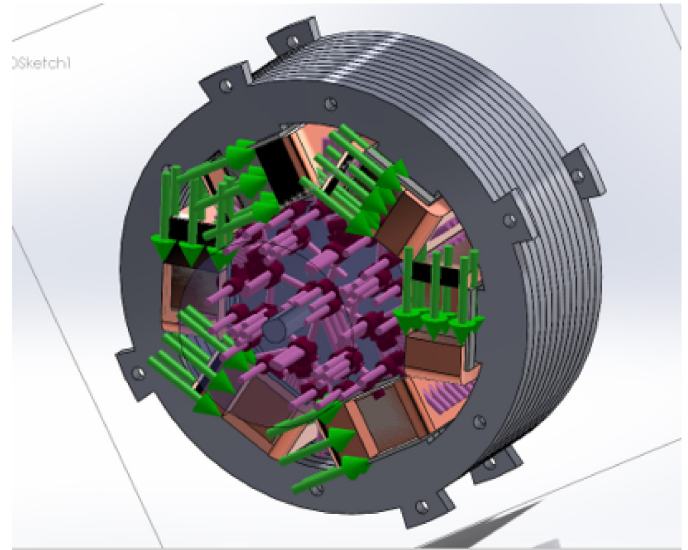

Fig. 7: The current definitions through the coils are assigned in the assembly, by specifying directions through the cross-sections of the coil parts, as illustrated by green vectors. The current can be both direct, for magnetostatic studies, and varying, for transient magnetic analysis. The wire gauge and number of turns of each coil are also specified, along with the material type of each part in the assembly.

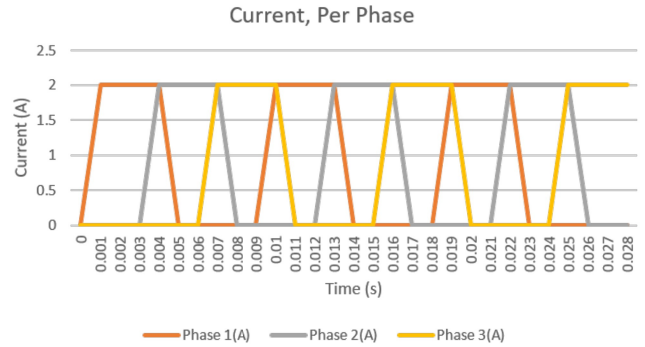

Fig. 8: The per-phase current profiles through each coil, as used in performance simulations of the final design.

in Fig. 10. This data is critical for the controls software of the motor. The simulated results are compared against the physical results of a prototype in the following section.

IV. RESULTS

The prototyping hardware is built and physical results are collected. The motor itself, complete with a 3D-printed prototype plate-type enclosure, encoder wheel, and rotor position sensor circuitry, is shown in Fig. 11. The prototype circuit board onto which the current driver surface mount chip is placed, which is used to recreate the per-phase current profiles used in simulations and graphed in Fig. 8, is shown in Fig. 12.

To test the prototype, the hardware was overclocked closer to its physical limits than the simulations, which were done to confirm that the hardware is capable of meeting the minimum output characteristic requirements.

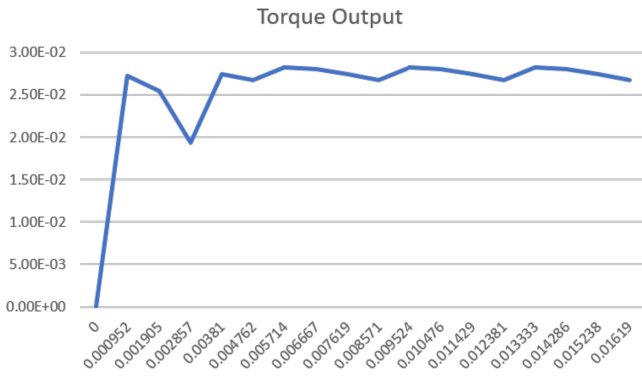

Fig. 9: The torque profile of the motion study of the final simulated design. A maximum torque of $0.028N \cdot m$ is achieved, with a ripple of about 0.2%.

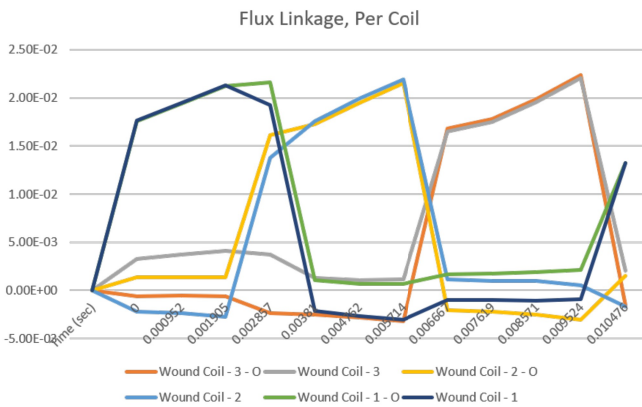

Fig. 10: The simulated per-coil-pair flux linkage data, which is crucial for the controls software of the robot, is collected and presented in the figure.

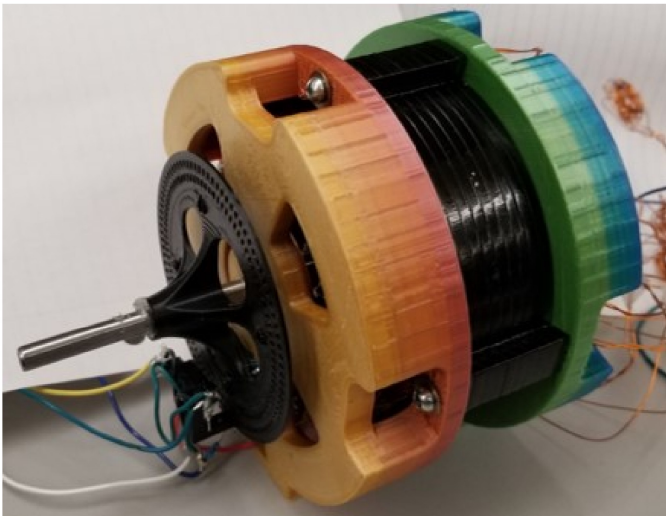

Fig. 11: The design outlined in sections I-III is built using ten powder-coated, waterjet-cut steel laminations. The 3D-printed prototype enclosure, encoder wheel, and rotor position circuitry used for controls are also displayed.

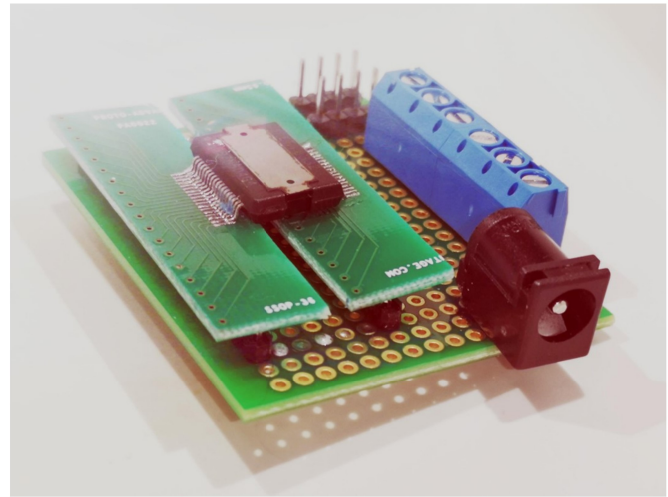

Fig. 12: A prototype circuit is built to mount the current driver surface mount chip, to recreate the current profile defined in EMS in Fig. 8.

As shown in Fig. 8, simulated current run through the coils operated the rotor at 1,000 RPM, with an amplitude of 2A of current. The overclocked results used current with an amplitude of 3A, and the rotor was able to maintain a steady output of 2,500 RPM, with only a 2% ripple, as graphed in Fig. 13.

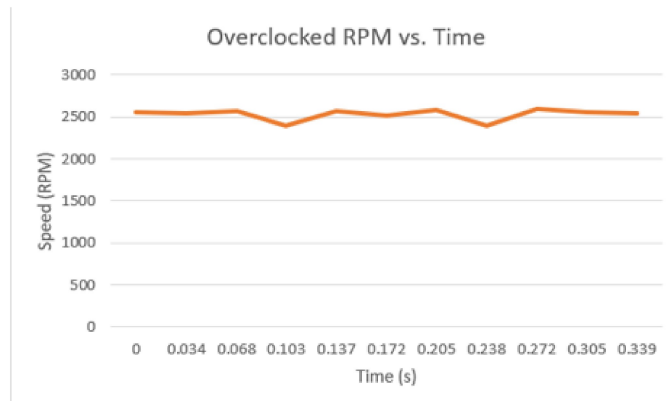

Fig. 13: The speed profile of the overclocked prototype motor shows that a steady speed of 2,500 rpm is achieved, with a ripple of only 2%.

The overclocked motor achieved an output starting torque of $0.1N \cdot m$, as measured using the apparatus shown in Fig. 14.

The overclocked motor thus achieved the characteristics as outlined in Table II. The motor surpassed the requirements, as necessitated by the controls portion of the project. As predicted by EMS, a prototype of the chosen motor design is capable of maintaining the minimum nominal characteristic values, as outlined in Table I.

TABLE II: Overclocked prototype motor characteristics.

Starting Torque ($N \cdot m$)	Speed (rpm)
0.1	2500

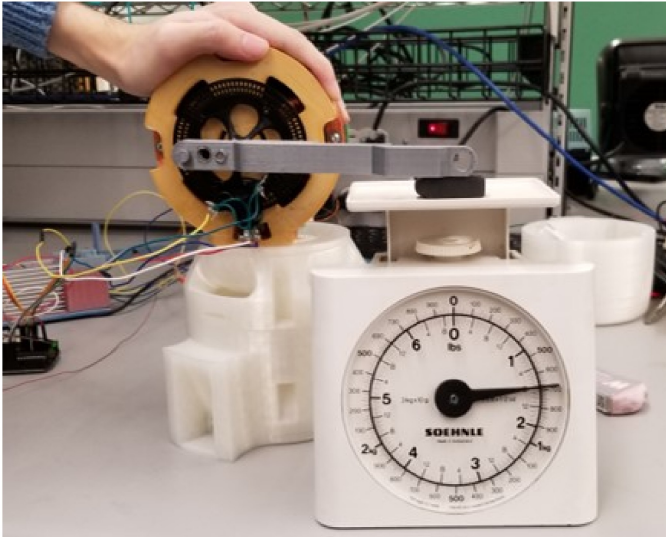

Fig. 14: The starting torque of the motor is calculated by measuring the force applied by the motor through a custom 3D-printed arm. It was determined that the overclocked prototype motor achieves a starting torque of $0.1N \cdot m$.

V. CONCLUSION

To meet the controls design requirements of the musical instrument-playing robot, as part of undergraduate, third year electrical engineering coursework at the University of British Columbia, modern small reluctance motor design principles were followed, as outlined in [1]. An iterative design approach was taken to maximize the efficiency of the final design. Given the resource constraints of the project, simulation software was key in validating design decisions. Through magnetostatic studies, transient magnetic analysis, and motion studies, the design was optimized to achieve the output characteristics of a motor prototype that surpasses the needs of the controls portion of the project. This work naturally extends to electromagnetic machines of all sizes and needs: for example, EMS can be similarly used to develop and validate designs of permanent magnet and induction machines.

ACKNOWLEDGMENT

The authors would like to thank EMWorks for making the project's success possible by providing a trial for the full Electromagnetic Simulation (EMS) software, the UBC Electrical and Computer Engineering Department for providing the funding necessary to complete the project, and our professor, Dr. Leo Stocco, for the invaluable guidance that helped make the project a success.

REFERENCES

- [1] B. B. J. W. J. A. Emadi, *Switched Reluctance Motor Drives: Fundamentals to Applications*. CRC Press.
- [2] EMWorks, "Ems product page, <https://www.emworks.com/product/ems>."